

IMPASSE II®



HIGH SECURITY STEEL PALISADE FENCING

Maintaining a secure perimeter is your first line of defense against potential threats. Impasse II fence systems serve as a *visual deterrent backed with heavy steel components* that give a higher level of protection compared to the traditional chain link or architectural mesh fence alternatives. Impasse II is the *best choice for securing at risk facilities or protecting specific assets within a property.*

DESIGN INTEGRATION

The Impasse II framework is a raceway for wiring, conduits, and/or security cabling required around the perimeter of a project. This integrated design eliminates the need for costly trenching and boring becoming a value added solution for perimeter security upgrades.

When installing these security elements use Impasse II as a platform:

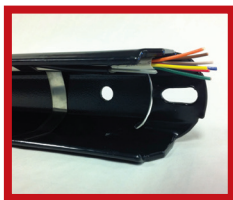

- ▶ Communication & Video Cables
- ▶ Intrusion Detection / Fiber Optic Cables
- ▶ Access Control Wiring
- ▶ Conduits
- ▶ Anti-Ram Cabling (Stalwart)

PRIMARY APPLICATIONS

- ▶ Military Sites
- ▶ Government Facilities
- ▶ Petroleum & Chemical Facilities
- ▶ Power Plants & Substations
- ▶ Airports
- ▶ Data Centers
- ▶ Ports of Entry
- ▶ Water Treatment & Storage



FENCE PRODUCTS

AMERISTARFENCE.COM | 888-333-3422

ASSA ABLOY, the global leader in door opening solutions

AMERISTAR®

ASSA ABLOY

IMPASSE II[®]

HIGH SECURITY STEEL PALISADE FENCING

2.75"w x 14ga PALES | 2" x 2" x 11ga RAILS | 3" x 2.75" x 12ga & 4" x 2.75" x 11ga I-BEAM POSTS

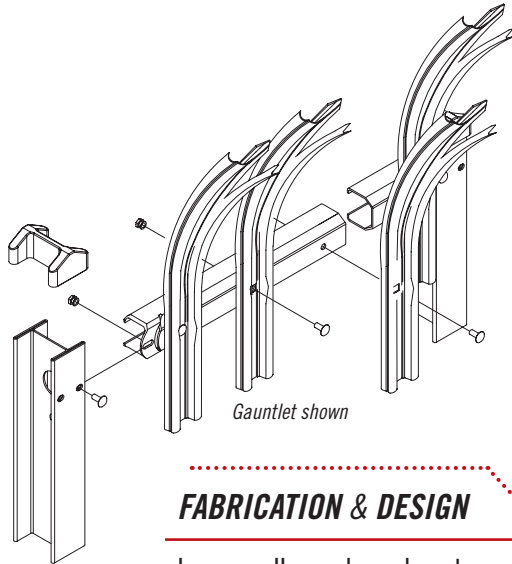

STYLE OPTIONS

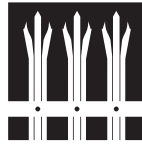

TRIDENT™



STRONGHOLD™

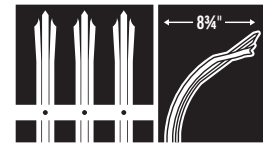

GAUNTLET™

Impasse II Anti-Scale option is also available

FABRICATION & DESIGN

Impasse II panels and posts are manufactured using high-tensile pre-galvanized G-90 steel. Each component has been roll-formed into a unique profile that yields significant strength properties. Impasse II's distinct design enables the fence to traverse aggressive changes in grade in order to maintain security along any perimeter. Each connection point of the Impasse II system is secured with tamper-proof fasteners providing the highest level of security and versatility.



PERMACOAT™ PROTECTIVE FINISH

Ameristar's production facilities use a state-of-the-art polyester powder coating system that provides a durable and scratch resistant finish. Impasse II is protected with Ameristar's PermaCoat multi-layer coating process. The combination of these layers delivers a system that increases weathering resistance and product durability. The Ameristar coating system results in finished surfaces with unmatched performance.



15 YEAR LIMITED WARRANTY

Impasse II is coated using Ameristar's PermaCoat process, this dual-coat finish yields the best results for durability and weathering in the fence industry. Ameristar has over 25 years of experience and research in coating fence products allowing Impasse to support a 15 year warranty.



DOMESTIC MANUFACTURING

Ameristar is committed to providing products that are manufactured in the USA. We have made significant investments in technology, process improvement, and employee training in an effort to secure American jobs and combat inferior import products.

#9792 | REVISED 05/2014



FENCE PRODUCTS

TO PLACE YOUR ORDER CALL 888-333-3422

VISIT AMERISTARFENCE.COM